

Model

Courtesy of

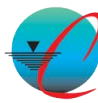

**CROFTON**  
INDUSTRIES

# 800 Series

TELESCOPIC  
BOOM LIFTS

**JLG**

## Features

6 ft (1.83 m) Articulating Jib (860SJ Only)  
Platform: 36 x 96 in. (0.91 x 2.44 m) Side Entry  
Inward Swinging Gate  
Dual-Rated Capacities  
SkyPower® Package  
Oscillating Axle  
Hydraulic Platform Rotator  
110V AC Receptacle in the Platform  
5 Degree Tilt Alarm/Indicator Light  
Swing-Out Engine Tray  
12V DC Auxiliary Power  
Hourmeter  
Fuel Gauge  
Control ADE® System  
All Motion Alarm  
Proportional Controls  
Gull-Wing Hoods  
Hydrostatic Drive  
Operators Tool Tray  
Platform Console Machine Status Light Panel\*  
Lifting/Tie Down Lugs  
Engine Distress Warning/Shutdown—  
Selectable via JLG Analyzer  
15-625 Rim Protector Lug Tread Tires  
Glow Plugs (Diesel Engines)

\* Provides indicator lights at platform control console for system distress, fuel level, low fuel, 5 degree tilt light and foot switch status.

## Accessories & Options

Platform: 36 x 72 in. (0.91 x 1.83 m)  
Fall Arrest Platform  
(Requires Foam Filled Tires)  
Mesh to Top Rail  
Light Package<sup>1</sup>  
Flashing Amber Beacon  
15-625 Foam Filled Tires  
18-625 Foam Filled Tires  
Soft-Touch System  
Catalytic Muffler  
Cold Weather Start Kit<sup>2</sup>  
Hostile Environment Kit<sup>3</sup>  
Arctic Package<sup>4</sup>  
Platform Worklights  
Tow Package  
Special Hydraulic Oils (Consult Factory)

### Accessory Packages:

SkyWelder®  
SkyGlazier®  
Nite Bright®  
SkyCutter®  
Pipe Rack  
SkyAir®

1. Includes platform mounted work lights and drive/backup lights.
2. Engine block heater, battery heater and oil tank heater.
3. Includes console cover, boom wipers and cylinder bellows.
4. Includes arctic hydraulic hoses (drive and steer only and main boom cable, arctic hydraulic oil, extreme cold engine oil, anti-freeze (CAT only), fuel conditioner, engine block heater, battery blanket, glow plugs, hydraulic tank heater and oversized foot switch.

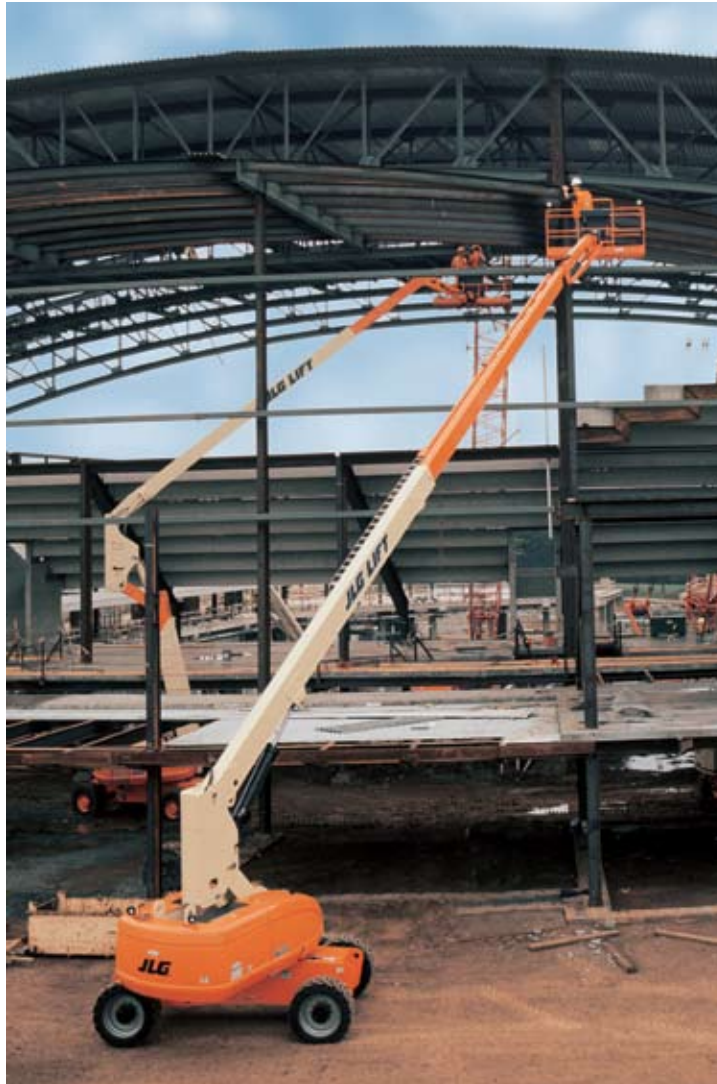

### Optimum Performance, Increased Productivity

- Go from ground to 80 ft (24.38 m) in less than 67 seconds—40% faster than competitive models
- Revolutionary Workstation in the Sky® accessory packages enhance the work environment and increase productivity

### Easier Maintenance, Reduced Costs

- Swing-out engine tray allows for faster and easier access for routine maintenance
- Exclusive Advanced Design Electronics (Control ADE®) System provides smoother machine functions, increased fuel efficiency and reduced emissions

### Higher Capacity and Improved Performance

- Dual-rated platform capacities up to 1,000 lb (454 kg)
- 45% gradeability and oscillating axle for improved traction

# 800 Series

## TELESCOPIC BOOM LIFTS

### Specifications

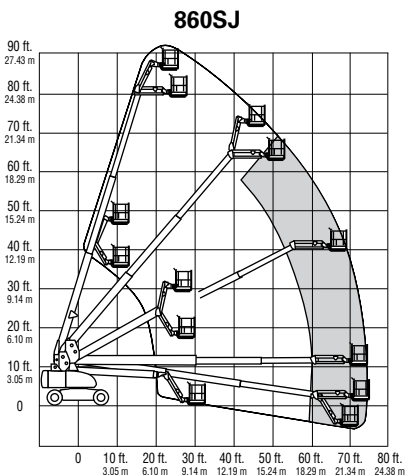
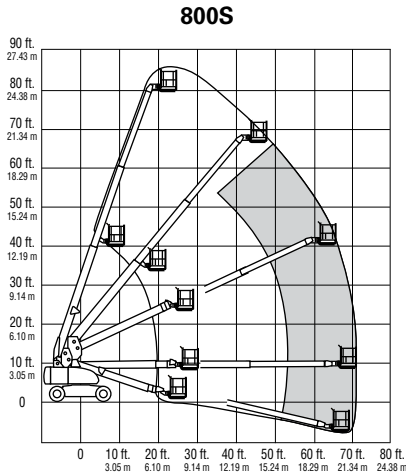

#### Reach

Platform Height	
800S	80 ft (24.38 m)
860SJ	86 ft (26.21 m)
Horizontal Outreach	
800S	71 ft (21.64 m)
860SJ	75 ft (22.86 m)
Swing	360° Continuous
Platform Capacity—	
Restricted (800S)	1,000 lb (454 kg)
Restricted (860SJ)	750 lb (340 kg)
Platform Capacity—	
Unrestricted	500 lb (227 kg)
Platform Rotator	180° Hydraulic
Jib Range of Articulation	
860SJ	130° (+70, -60)

#### Dimensions

A. Platform Size	36 x 96 in. (0.91 x 2.44 m)
B. Overall Width	8 ft 2 in. (2.49 m)
C. Tailswing (working condition)	4 ft 8 in. (1.42 m)
D. Stowed Height	
800S	9 ft 11 in. (3.02 m)
860SJ	10 ft (3.05 m)
E. Stowed Length	
800S	37 ft 3 in. (11.35 m)
860SJ	40 ft (12.19 m)
F. Wheelbase	10 ft (3.05 m)
G. Ground Clearance	12 in. (30 cm)
Weight <sup>1</sup>	
800S	33,200 lb (15,060 kg)
860SJ	36,400 lb (16,511 kg)
Max. Ground Bearing Pressure	
800S	72 psi (5.06 kg/cm <sup>2</sup> )
860SJ	81 psi (5.69 kg/cm <sup>2</sup> )

#### Chassis

Drive Speed 2WD	3.5 mph (5.6 kmph)
Drive Speed 4WD	3.5 mph (5.6 kmph)
Gradeability 2WD	30%
Gradeability 4WD	45%
Tires	15.625 Pneumatic
Turning Radius	
Inside	12 ft (3.66 m)
Outside	22 ft 6 in. (6.86 m)

1. Certain options or country standards increase weight.

#### Power Source

Dual Fuel Engine,	
GM Vortec 3000 MPFI	82 hp (61 kW)
Diesel Engine,	
Deutz D2011L04 with EGR	64 hp (47 kW)
Diesel Engine,	
Caterpillar C3.4	63.3 hp (47.2 kW)
Fuel Tank Capacity	31 gal (117.3 L)
Hydraulic Reservoir	48 gal (181.7 L)
Auxiliary Power	12V DC

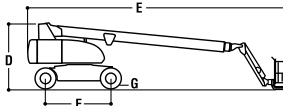
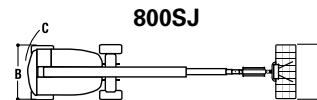
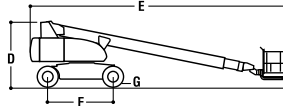
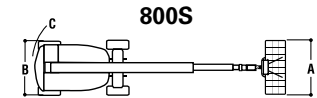

#### The JLG "1 & 5" Warranty

JLG Industries, Inc. backs our products with our exclusive "1 & 5" Warranty. We provide coverage for one (1) full year, and cover all specified major structural components for five (5) years. These machines meet or exceed applicable OSHA Regulations in 29 CFR 1910.67, 29 CFR 1926.453, ANSI A92.5-2006 and CSA standard B354.4-02 as originally manufactured for intended applications. We reserve the right to make price, specification, and/or equipment changes without prior notification.



#### JLG Industries, Inc.

1 JLG Drive  
McConnellsburg, PA 17233-9533  
Telephone 717-485-5161  
Toll-free in US 877-JLG-LIFT  
Fax 717-485-6417

[www.jlg.com](http://www.jlg.com)

An Oshkosh Corporation Company