

Courtesy of



CROFTON
INDUSTRIES

GROVE® RT60S

SELF-PROPELLED

HYDRAULIC CRANE

18 TON CAPACITY

Meets requirements of P.C.C.A. Standard No. 2



HYDRAULIC CRANES

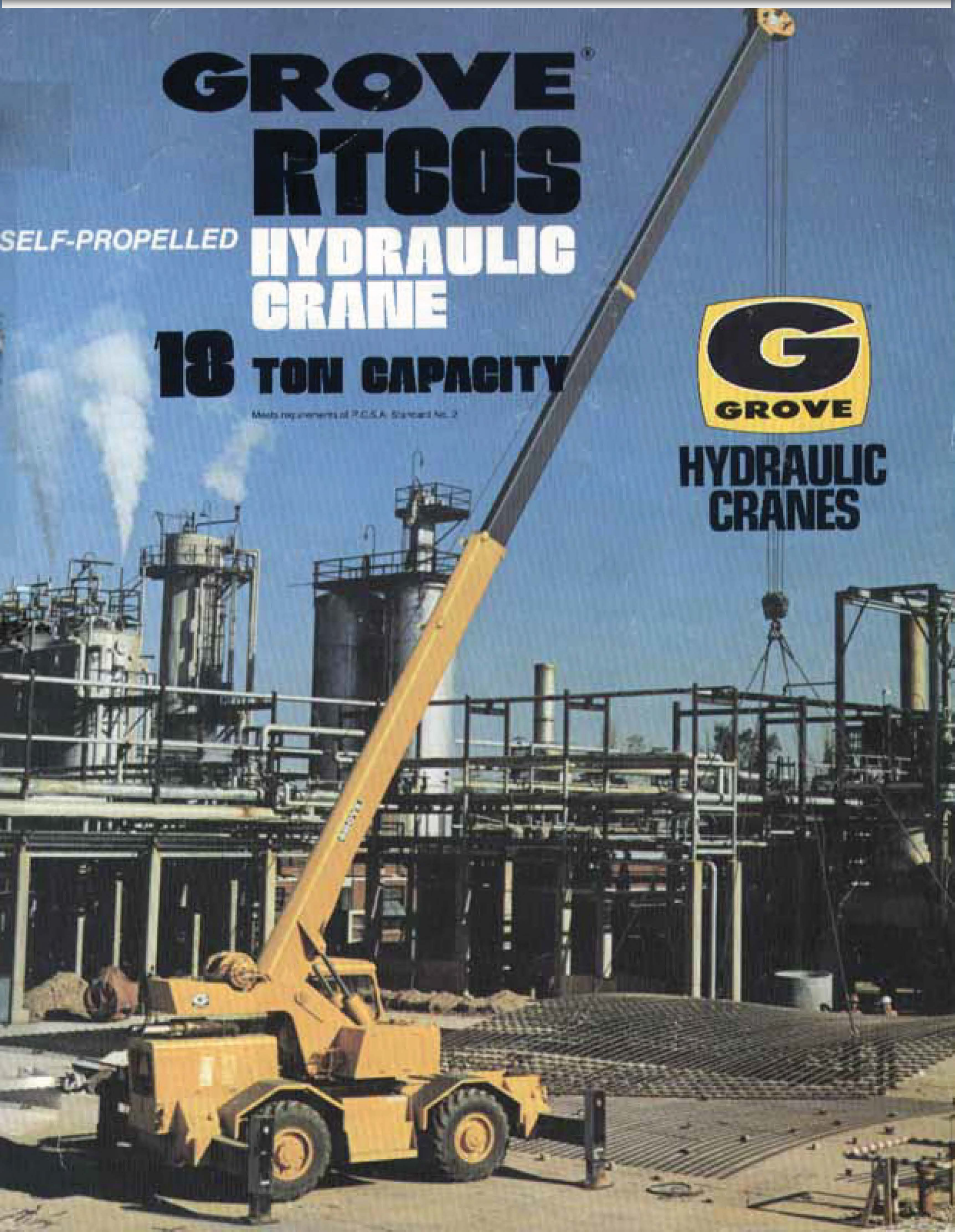



ROUGH TERRAIN MOBILITY . . . An automatic lock-out is provided to prevent rear suspension system oscillation whenever the boom is in other than the forward position. An optional no-spin differential for the rear axle is also available. Rear axle and hydraulic pump disconnects provide more efficiency while traveling.

TURNTABLE-MOUNTED CAB DESIGNED FOR OPERATOR CONVENIENCE! . . . There is never a blind spot for the operator as the cab swings with the boom, keeping the operator facing the load at all times. The cab features a large hinged, tinted skylight, a removable front windshield and sliding side and rear windows for ventilation. Both driving and crane controls fall readily-to-hand and are arranged in a consistent Grove pattern for operator convenience.

SMOOTH PRECISE LIFTS . . . Grove planetary gear drive hoist, power up and down, is standard. Hoist and lowering speeds can be controlled from zero to maximum under all load conditions.

TOOL STORAGE is provided in a large covered storage well located forward on the chassis deck.

***THE KRUGER LOAD MOMENT INDICATOR AND ANTI-TWO BLOCK SYSTEM** (optional) senses critical operational factors of the crane and compares them with rated lifting capacities while providing the operator with a continuous visual display of crane conditions by means of a large dash-mounted instrument with color-coded scale. An integral audio and visual warning system alerts the operator if an overload or two-block condition approaches, while the Grove automatic bypass circuitry diverts the oil flow from those functions which contribute to an overload or two-block condition, permitting operation of only those crane functions that will improve the situation.

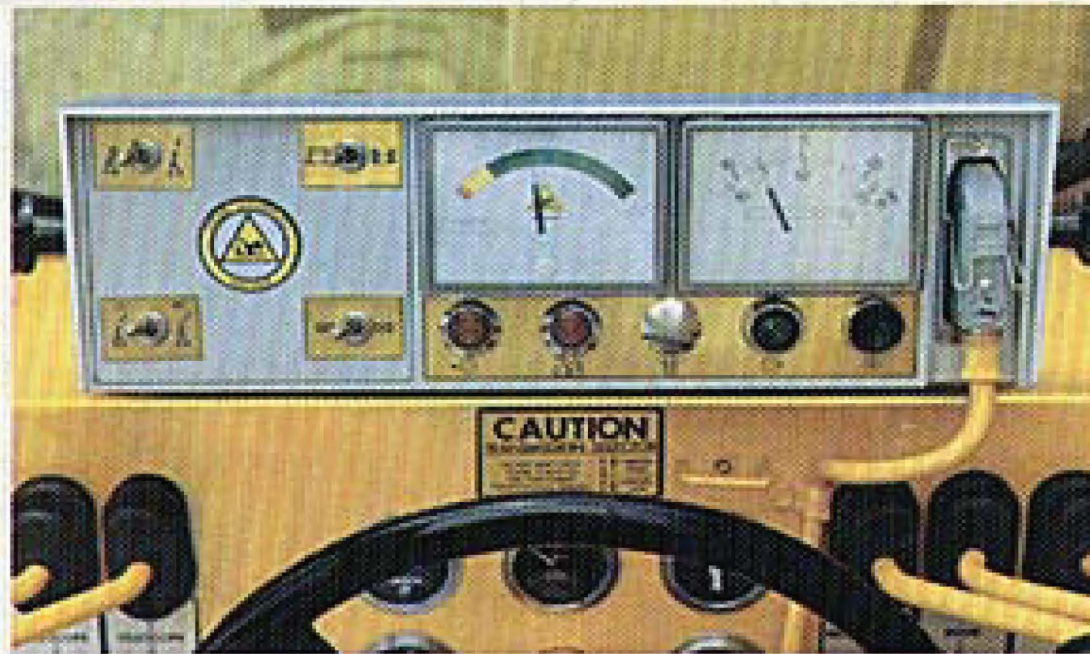
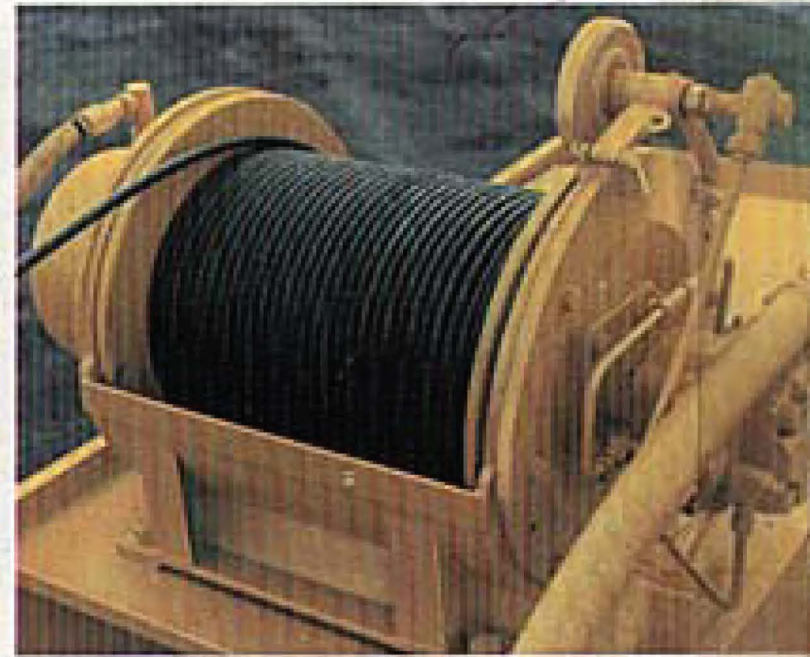
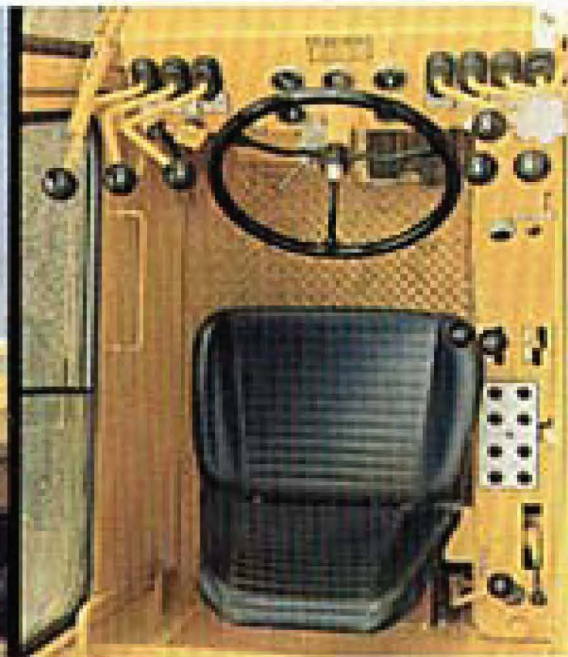



RT605

RIGID BOOMS . . . are of welded-box design, fabricated of high strength steel purchased to Grove specifications. Boom design is clean with all boom telescoping cylinders and hydraulic hoses totally enclosed. Side adjustable, boom-mounted wear pads prevent metal-to-metal contact of the inner telescoping boom sections thus boom telescoping action is always smooth and precise during extension and retraction. Integral holding valves are standard on all telescoping cylinders.

Illustrated is the standard 70' (21.3m) boom. The optional 78' (23.8m) 4-section boom with 19' (5.8m) jib provides a tip height of 103' (31.4m) with a capacity of 6,200 lbs. (2812kg).

OPTIMUM STABILITY FOR 360° LIFTING CAPABILITY! . . . Individually controlled hydraulic outriggers in a nearly square configuration provide the necessary stability for high capacity lifting in a 360° arc. Outriggers are independently set or retracted by a special safety control arrangement which makes it virtually impossible to accidentally retract the outriggers once set. Double-box sliding beam outriggers and box-type vertical jacks protect the hydraulic cylinders from the elements and job-site damage. Mechanical pin locks and holding valves are standard features.

OUTSTANDING MANEUVERABILITY! . . . Tight quarter operation is a common occurrence for RT Cranes and that's why Grove RT Cranes offer the ultimate in maneuverability with full-power hydraulic steering on both axles. This permits 4-wheel coordinated, 4-wheel crabbing, 2-wheel (front or rear) steering for better maneuverability. Grove's system of independent control for each axle permits a greater degree of maneuverability with greater ease for the operator.





SPECIFICATIONS

ENGINE SPECIFICATIONS

MAKE & MODEL	Cummins Diesel V-504C	*Detroit Diesel 4-53N	*Caterpillar Diesel 3208
TYPE	8 Cylinder OHV	4 Cylinder OHV	8 Cylinder OHV
BORE & STROKE	4.625 in. x 3.75 in. (117mm x 95mm)	3.875 in. x 4.50 in. (99mm x 114mm)	4.5 in. x 5.0 in. (114mm x 130mm)
DISPLACEMENT	504 cu. in. (8259cm ³)	212 cu. in. (3474cm ³)	636 cu. in. (10 422cm ³)
HORSEPOWER (NET)	142 @ 2600 RPM	109 @ 2800 RPM	122 @ 2500 RPM
GOVERNED RPM	2600 RPM	2800 RPM	2500 RPM
TORQUE (NET)	303 lbs. ft. (42kg.m) @ 1800 RPM	236 lbs. ft. (33kg.m) @ 1800 RPM	344 lbs. ft. (48kg.m) @ 1100 RPM
ELECTRICAL SYSTEM	12-volt, Negative Ground	12-volt, Negative Ground	12-volt, Negative Ground
COMBUSTION SYSTEM	4 Cycle, Naturally Aspirated	2 Cycle, w/blower	4 Cycle, Naturally Aspirated
COOLING SYSTEM	Liquid	Liquid	Liquid
FUEL CAPACITY	50 Gallons (189 liters)	50 Gallons (189 liters)	50 Gallons (189 liters)
ALTERNATOR	55 Amp, 12-volt	65 Amp, 12-volt	55 Amp, 12-volt
BATTERY	(2) 12-volt 1500 CCA @ 0°F	(1) 12-volt 825 CCA @ 0°F	(2) 12-volt 1500 CCA @ 0°F
AIR CLEANER	Dry Type	Dry Type	Dry Type
AIR COMPRESSOR	13.2 CFM (374 lpm)	7.25 CFM (205 lpm)	12 CFM (340 lpm)
HOURMETER	Yes	Yes	Yes

*Denotes optional equipment

SPEED AND GRADEABILITY

Forward Drive	Transmission Range	Gear Shift	Maximum Speed		Max. Gradeability @ Stall %	Max. Tractive Effort At Stall	
			MPH	KM/H		LB.	KG.
4 Wheel Drive	Low	1st	2.7	4.3	87.3	32,515	14 749
4 Wheel Drive	Low	2nd	5.1	8.2	35.9	17,176	7791
4 Wheel Drive	Low	3rd	13.8	22.2	11.2	6,292	2854
2 Wheel Drive	High	1st	6.4	10.3	27.5	13,672	6202
2 Wheel Drive	High	2nd	12.1	19.5	13.1	7,210	3270
2 Wheel Drive	High	3rd	28.5	45.9	3.5	2,652	1203

NOTE: All performance data is based on standard machine and may vary plus or minus 10% due to variations in engine performance and vehicle weight.

WORKING WEIGHTS

Standard Machine With	Total Weight		Axle Weight Distribution			
	Lbs.	Kg.	Front		Rear	
	Lbs.	Kg.	Lbs.	Kg.	Lbs.	Kg.
28-70 ft. (8.5m - 22.3m) boom	47,980	21 764	28,620	12 982	19,360	8782
*24-60 ft. (7.3m - 18.3m) boom	46,820	21 238	24,160	10 959	22,660	10 279
*24-78 ft. (7.3m - 23.7m) boom	48,425	21 986	27,400	12 429	21,025	9537

NOTE: Weights may vary plus or minus 3% due to manufacturing tolerances.

*Denotes optional equipment.

DIMENSIONS

TIRE SIZE	A	B	C	D	E	F1	F2
18:00 x 24	59 3/8 in. (1508mm)	77 1/2 in. (1969mm)	95 5/8 in. (2429mm)	13 1/2 in. (343mm)	26 in. (660mm)	23°	19°
*20.5 x 25	59 1/2 in. (1502mm)	81 1/8 in. (2061mm)	103 1/8 in. (2619mm)	14 1/2 in. (368mm)	26 13/16 in. (681mm)	21°	18°

*Denotes optional equipment

BOOM LENGTH	G	H	I
*24-60 ft. (7.3m - 18.3m)	11 ft. 2 1/2 in. (3416mm)	31 ft. 6 3/8 in. (9617mm)	8 ft. 8 1/4 in. (2648mm)
28-70 ft. (8.5m - 21.3m)	15 ft. 2 1/2 in. (4636mm)	35 ft. 6 3/8 in. (10 836mm)	8 ft. 9 5/8 in. (2675mm)
*24-78 ft. (7.3m - 23.7m)	11 ft. 1/4 in. (3359mm)	31 ft. 4 5/8 in. (9558mm)	8 ft. 8 1/4 in. (2648mm)

Tall Swing - 10 ft. 3 3/4 in. (3131mm)
Turning Radius - 15 ft. 10 in. (4826mm)

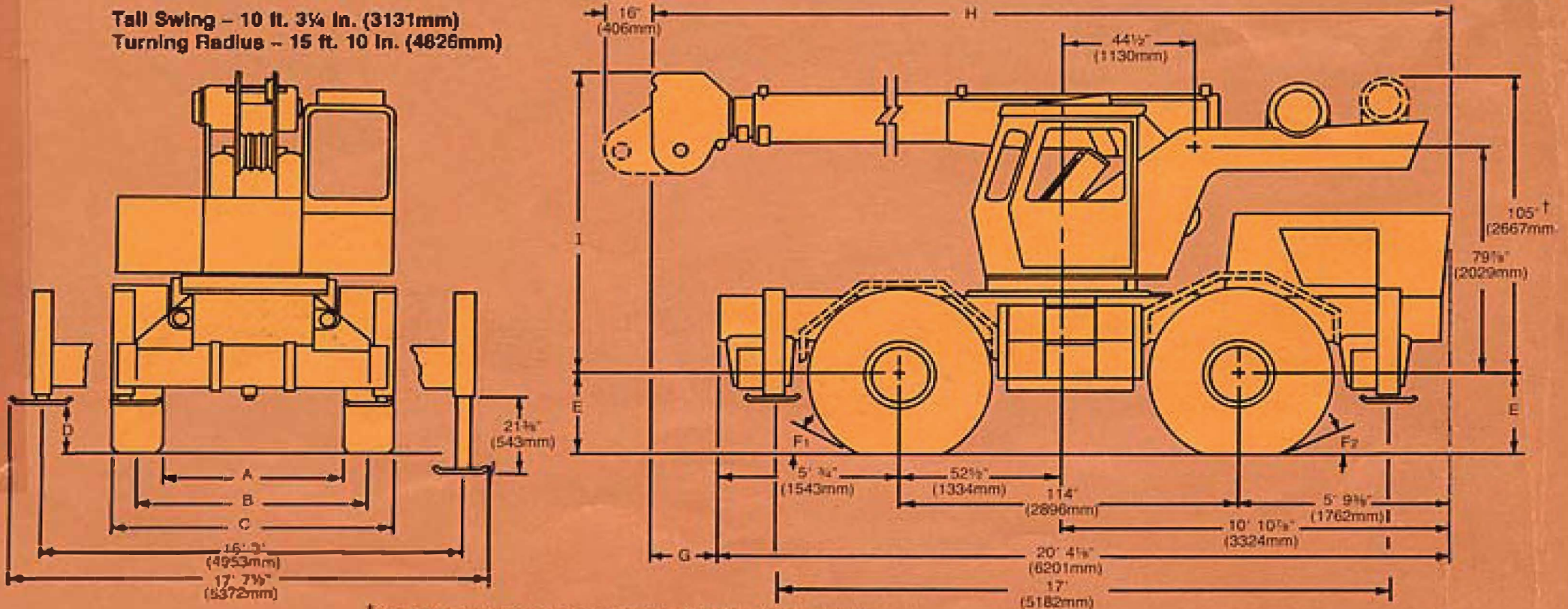

† 106.5 (2705mm) with Model 11 controlled free fall hoist as auxiliary.

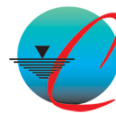

SPECIFICATIONS

BOOM – 28 ft. – 70 ft. (8.5m – 21.3m), 3 section, full power telescoping *24 ft. – 60 ft. (7.3m – 18.3m), 3 section, full power telescoping. *24 ft. – 78 ft. (7.3m – 23.8m), 4 section, power telescoping. Two full power sections to 60 ft. (18.3m) plus an 18' (5.5m) fly section power extended and retracted from pinned position. Pendulum boom angle indicator. Integral holding valves on each telescoping cylinder. Boom telescope sections are individually controlled and supported on graphite impregnated nylon wear pads. Side adjustable wear pads prevent metal-to-metal contact of inner boom sections.

BOOM NOSE – Three 1 1/4" tread dia. (286mm) sheaves mounted on heavy duty needle bearings. Removable pin type rope guards allow easy reeving. Rope dead ends on one side of boom nose. * (Single sheave 1 1/4" tread dia. (286mm) auxiliary boom nose mounted to main boom nose, with removable pin-type rope guard. For single part line work.)

BOOM ELEVATION – Dual 8 1/4" (210mm) bore double-acting cylinders with integral holding valves; 0° to 75° elevation.

***LOAD MOMENT AND ANTI-TWO BLOCK SYSTEM (KRUGER)** – Audio-visual warning in combination with automatic by-pass of: hoist up, boom telescope out, and boom down functions.

***JIBS** – 19 ft. (5.8m) "Stowaway" for 24 ft. – 60 ft. (7.3m – 18.3m) and 24 ft. – 78 ft. (7.3m – 23.8m) booms. 23 ft. (7.0m) "Stowaway" for 28 ft. – 70 ft. (8.5m – 21.3m) boom. All jibs have self-equalizing suspension and jib backstops.

SWING – Ball bearing swing circle, 360° continuous rotation. Grove planetary "Glide Swing" with foot-operated disc swing brake and cab-controlled positive (plunger type) turntable lock. Swing speed 3.1 RPM. (Non-free swing optional)

CAB – Turntable-mounted, full vision, all steel, fully enclosed with tinted, tempered glass throughout and hinged skylight: (windshield laminated). Left side door with lock, side sliding windows with locks. Full length control levers, fully adjustable operator's seat. Complete engine instrumentation and driving controls. Combination hand and foot throttle. All-crane super-structure and outrigger controls, 20,000 BTU diesel fuel heater, electric windshield wiper, dome light, front cab-mounted work lights, defroster fan, air horn, 3 1/2 lb. (1.7kg) dry-type fire extinguisher.

CAB INSTRUMENTATION – Engine oil pressure gauge, engine water temperature gauge, voltmeter, electric fuel gauge, air pressure gauge, transmission and torque converter oil temperature gauge, engine hourmeter, low air pressure visual warning. Hoist rotation indicator.

OUTRIGGERS – Hydraulic, double-box, integral with main frame; telescoping beams, enclosed vertical jacks with integral holding valves and mechanical pin locks. Independent or simultaneous control in-out-up-and-down. Outrigger controls in operator's cab. Sequence control arrangement virtually eliminates accidental outrigger actuation.

MAIN FRAME – All-welded construction with full depth longitudinals braced by cross-members. Frame reinforced at critical points to insure a rigid turntable mounting.

TRANSMISSION AND TORQUE CONVERTER – Engine-mounted converter with PTO for hydraulic pumps. Remote mounted full powershift transmission with rear axle disconnect.

SPEEDS – 6 forward and 6 reverse.

AXLES – Front: Planetary drive/steer type mounted rigid to frame.
Rear: Planetary drive/steer type mounted to allow 0 in. to 9.5 in. (0 – 241 mm) oscillation. (No splin rear axle optional.)

OSCILLATION LOCKOUTS – Automatic hydraulic on rear axle. Allows oscillation only with boom over front.

SERVICE BRAKES – Full air on all four wheels. Size: 20 1/4 in. x 4 in. (514mm x 102mm). Total lining area: 644 sq. in. (415cm²).

PARKING BRAKES – Front and rear axles equipped with "Fall Safe" spring set emergency and parking chambers.

STEERING – Front: Full power assist hydraulic control.
Rear: Full hydraulic, tiller bar control. Independent front and rear steer control allows maximum "on the move" maneuverability.

TIRES – 16:00 x 24 – 16 ply tubeless, heavy duty grader.
*20.5 x 24 – 20 ply tubeless, high flotation earth mover.

***TOW WINCH** – Braden PD15 planetary, front-mounted, cab-controlled with 15,000 lb. (6804kg) single line pull and 145 FPM (44.2mpm) single line speed under full load (less rope and hook).

HYDRAULIC SYSTEM:

RESERVOIR – 82.6 gallon (312.6 liter) capacity, all-steel welded construction with integral baffles, clean out access and sight level gauge.

FILTER – Return line type with replaceable cartridge and by-pass protection 10 micron rating.

PUMPS – 3 main gear pumps, 112.5 GPM (426 lpm) combined capacity. Power steering pump 18.7 GPM (71 lpm) capacity. Pump disconnect lever operated from carrier deck.

CONTROL VALVES – Precision four-way double-acting with integral load check, main and circuit relief valves. Three individual valve banks permitting simultaneous independent control of three crane functions. Maximum operating pressure 2500 PSI. (175.8kg/cm²)

OIL COOLER – Full flow, fin and tube, oil to air.

POWER DISTRIBUTION – [Main hoist, *auxiliary hoist, 46.5 GPM (176 lpm)]; [Boom elevation, rear steer, mid telescope, main hoist boost, 39.5 GPM (149.5 lpm)]; [Fly telescope, outrigger, swing, 26.5 GPM (100.3 lpm)].

MISCELLANEOUS – Front storage well, hydraulic and fuel step tanks, protective seal fuel cap, right side rear view mirror, full engine hood.

*Denotes optional equipment.

HOIST SPECIFICATIONS

DESCRIPTION: Power up and down, equal speed, planetary reduction with integral automatic brake and hoist drum rotation indicator.			
HOIST DATA	MAIN HOIST Grove Model 15H-16B	*AUXILIARY HOIST Grove Model 15S-11B	*MAIN OR AUXILIARY HOIST Gearmatic Model 11 SGECR (Controlled Free Fall)
Drum Dimensions	12 in. dia. (305mm) 16 in. length (406mm) 17.5 in. dia. flange (445mm)	12 in. dia. (305mm) 11 in. length (279mm) 17.5 in. dia. flange (445mm)	9 in. dia. (229mm) 13 in. length (330mm) 17.5 in. dia. flange (445mm)
Performance: Max. Single Line Speed Max. Single Line Pull	355 FPM (108m/min) 9,165 lb. (4157kg)	200 FPM (61m/min) 9,165 lb. (4157kg)	290 FPM (88m/min) 9,145 lb. (4148kg)
Drum Rope Storage Capacity	**720 ft. of 1/2 in. dia. rope (219.5m of 13mm)	489 ft. of 1/2 in. dia. rope (149.1m of 13mm)	675 ft. of 1/2 in. dia. rope (208m of 13mm)
Permissible Single Line Rope Pull	1/2 in. (13mm) 6x37 class – 7,200 lb. (3266kg) 1/2 in. (13mm) 19x7 class – 6,150 lb. (2790kg)	1/2 in. (13mm) 6x37 class – 7,200 lb. (3266kg) 1/2 in. (13mm) 19x7 class – 6,150 lb. (2790kg)	1/2 in. (13mm) 6x37 class – 7,200 lb. (3266kg) 1/2 in. (13mm) 19x7 class – 6,150 lb. (2790kg)

*Denotes optional equipment

**6th layer of rope not recommended for hoisting operations.

Courtesy of

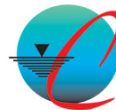

CROFTON
INDUSTRIES



RT60S

Another high availability crane in the Grove complete line of rough terrain cranes. This high efficiency crane offers quick set-up . . . extraordinary maneuverability . . . big payloads over a wide working radii . . . no operator blind spots . . . high travel speeds . . . established reliability and less down time. They are Grove values measurable in dollars and cents performance.



HYDRAULIC CRANES

GROVE MANUFACTURING COMPANY

Division of Walter Kidde & Company, Inc.

KIDDE

SHADY GROVE, PA 17256 U.S.A.